

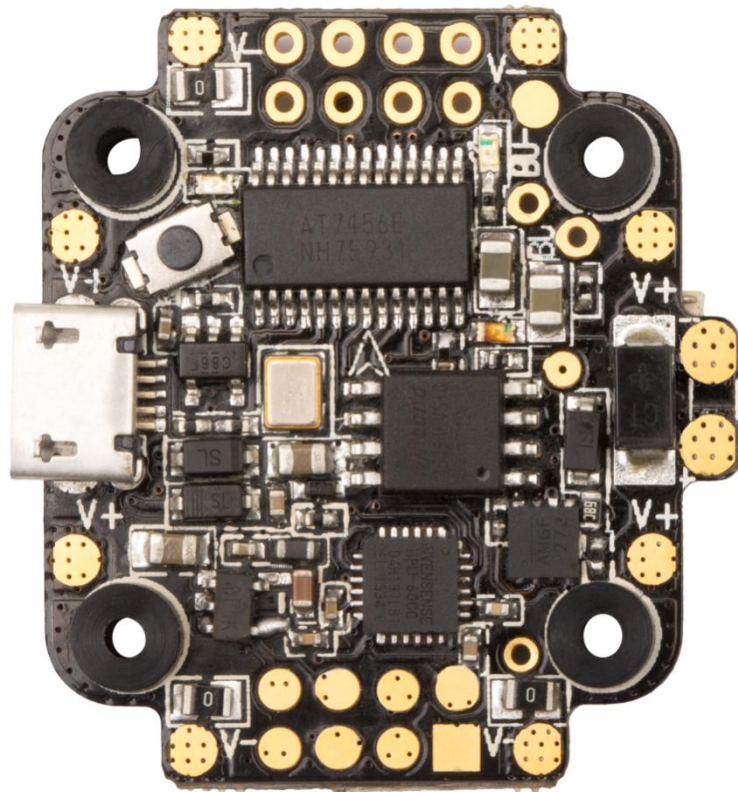

Manual Of DYS-MINI F4



Brief Introduction

DYS MINI F4 flight control with high performance which is designed for FPV hobbyists. Not only put PCB board together with flight control, but also integrated OSD, current meter, voltmeter and built-in high power BEC etc functions.

DYS MINI F4 flight control can meet all the functions you need include FPV racer, aerobatic flight and aerial photograph.

Basic Functions

- Betaflight firmware
- DYS F4 PRO firmware can be used
- STM32F405 master with higher refresh rate and more function ports
- Six-layer PCB board and 3OZ cooper to enhance the over-current and heat dissipation
- Six axis sensor MPU600 connects by SPI
- Compatible all split-type escs
- Microcontroller controls OSD chip through SPI bus DMS mode and faster speed
- Support BF setting software to flash and debug OSD
- 5V power supply max up to 2A

- Use remote control to view flight control parameter through OSD
- Support SAMRT AUDIO, IRC TARAMP agreement, adjust the VTX frequency and power etc by flight control (will support DYS new VTX)
- Comes with heat resistance damping ball to upgrade the stability and operation
- 2-4s lipo input support, with the anti-ignition function TVS device
- Net weight 6g without cable
- Dimension L 30mmX W 27mm, hole distance 20X20mm

Caution

Please be attention to below notes to protect your flight control and ensure your flight control stable

- Be attention to the polarity, please double check before power on
- While pull/plug or connection, please cut off the power
- Do not short the 5V or any other power, otherwise the flight control will burn
- Damping ball should be installed on the flight control (Already mounted before leaving the factory)
- While mount with 4-in-1 esc, please check the plugged pin correct or

not, be attention that do not force to pull or plug

- The maximum refresh rate of PID and gory up to 8K

1.Specification:

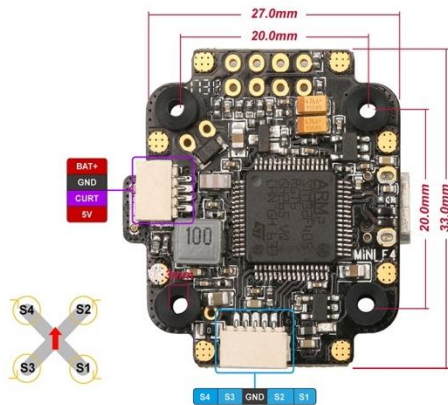

Data:

Size: L 33mmX W 30mm, hole distance 20X20mm

Master: STM32F405 GRT6

Enable voltage: 2-4s lipo input

Withstand current: 80A

BEC: 5V 2A

Net weight: 6g

2. Connection:

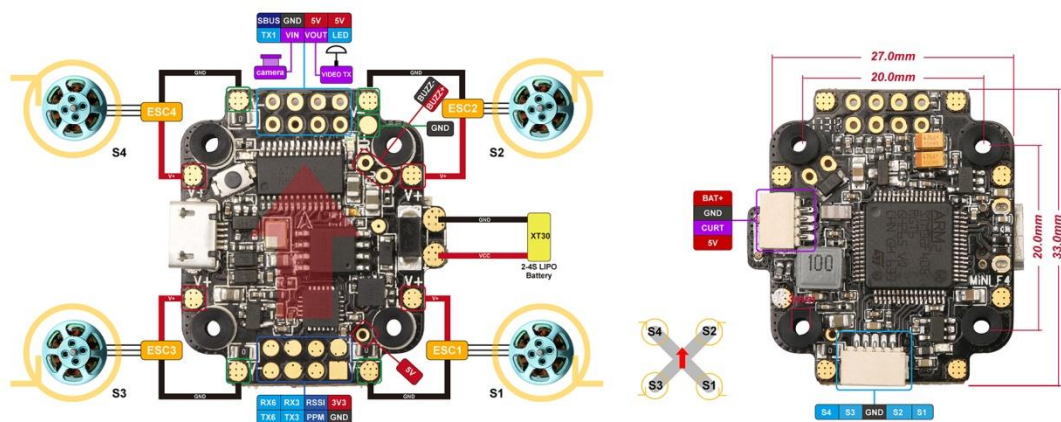

ESC S1-S4: For esc power cable

BOOT: BOOT button(for flash firmware)

5V: With 2A output for VTX, receiver and camera in the meantime

GND: Ground wire

Vout: Video output for VTX image signal wire

Vin: Video input for camera signal wire

LED: Programmable LED signal wire output

SUBS: Connect with subs receiver, Usart6 rx, Smart Audio(Usart6 tx):
serial port for Usart6, wiring for Smart Audio of VTX(OSD adjust
VTX)

Buzz-, Buzz+: Wiring for buzzer

UART3-TX,URAT3-RX: Serial port of URAT3

3. Mount for DYS 4-in-1 18A esc (optional)

1) Signal connection wire of DYS mini 4-in-1 esc through flat cable



2) Plug the mini F4 back flat cable with esc signal port

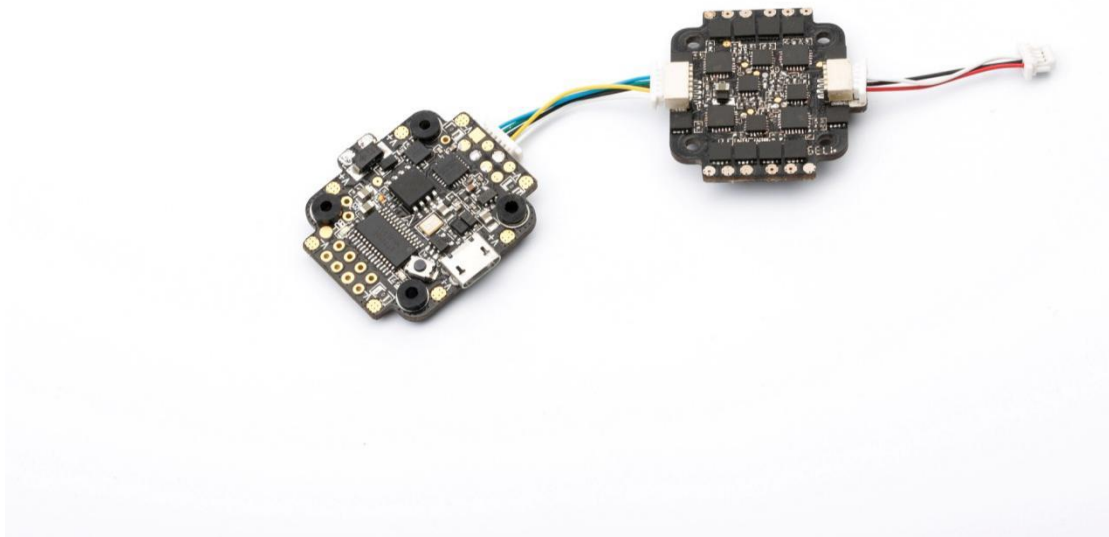

Note:

- Please mount the mini F4 with the 4-in-1 esc as pic shows. Be attention that do not avoid damage the socket

While using with 4-in-i esc

- Please solder the battery power cable with esc power cable, do not connect with battery
- Flight control and 4-in 1 esc of 5V(2A) are used independently, just need the esc connects with battery
- With voltage detection for battery

